

JP-2000-147528E

[Title of the Invention] METHOD FOR MANUFACTURING LIQUID
CRYSTAL DISPLAY DEVICE

[Abstract]

[Object] To realize a method for manufacturing liquid crystal display device capable of removing a positional deviation at the time of mutually sticking upper and lower substrates and removing defects such as uneven images.

[Solving Means] A lower substrate 3 whose upper surface is coated with an adhesive 1 and to which a liquid crystal (LC) material 2 is dropped is arranged in a vacuum container C, the whole lower surface is fixed by vacuum suction using a suction mechanism 5, an upper substrate 12 is arranged so as to be opposed to the lower substrate 3 at a prescribed interval, and the whole upper surface is fixed by vacuum suction using a suction mechanism 7. Then both the substrates 3 and 6 or either one of them are approached so as to bring the upper substrate 12 into contact with the liquid crystal material 2 or the adhesive 1 and both the substrates 3 and 6 are relatively moved in a substrate surface direction to align them. Then both the substrates 3 and 6 or either one of them are approached to each other and mutually pressurized to stick both the substrates 3 and 6 to each other.

[Claims]

[Claim 1] A method for manufacturing a liquid crystal display device the steps of arranging a lower substrate whose upper surface is coated with an adhesive and to which a liquid crystal material is dropped in a vacuum container and fixing the whole lower surface of the lower substrate with vacuum suction, arranging an upper substrate so as to be opposite to the lower substrate at a prescribed interval and fixing the whole upper surface of the upper substrate with vacuum suction, approaching both or either one of the substrates to each other so as to bring the upper substrate into contact with the liquid crystal material or the adhesive, relatively moving both the substrates in a substrate surface direction to align the substrates, approaching both or either one of the substrates to each other to pressurize both the substrates to each other, and sticking both the substrates to each other.

[Claim 2] A method for manufacturing a liquid crystal display device the steps of arranging a lower substrate whose upper surface is coated with an adhesive and to which a liquid crystal material is dropped in a vacuum container and fixing the whole lower surface of the lower substrate with vacuum suction, arranging an upper substrate so as to be opposite to the lower substrate at a prescribed interval and fixing the whole upper surface of the upper substrate

with vacuum suction, approaching both or either one of the substrates to each other at a prescribed interval location, relatively moving both the substrates in a substrate surface direction to perform pre-alignment, approaching both or either one of the substrates so as to bring the upper substrate into contact with the liquid crystal material or the adhesive, relatively moving both the substrates in a substrate surface direction to align the substrates, approaching both or either one of the substrates to each other to pressurize both the substrates to each other, and sticking both the substrates to each other.

[Claim 3] The method according to Claim 1 or 2, wherein the upper substrate is held at a location having a micro-gap with the adhesive when bringing the upper substrate into contact with the liquid crystal material or the adhesive.

[Claim 4] The method according to Claim 1 or 2, wherein an elastic body is interposed between the lower substrate and a vacuum suction mechanism.

[Claim 5] The method according to Claim 1 or 2, wherein, the suction of the lower substrate is released after the lower substrate and the upper substrate are stuck to each other.

[Claim 6] The method according to Claim 1 or 2, wherein the suction of the lower substrate is released after the lower substrate and the upper substrate are stuck to each

other, and the lower substrate and the upper substrate are temporarily fixed to each other by an ultraviolet ray curing type adhesive after the pressure of the vacuum container is returned to the atmospheric pressure.

[Claim 7] The method according to Claim 1 or 2, wherein the suction of the lower substrate is released and the pressure of the vacuum container is returned to the atmospheric pressure after the lower substrate and the upper substrate are stuck to each other and temporarily fixed to each other by an ultraviolet ray curing type adhesive.

[Claim 8] The method according to Claim 1 or 2, wherein the location of at least one of the upper substrate and the lower substrate is controlled by a controlling mechanism.

[Detailed Description of the Invention]

[0001]

[Technical Field of the Invention]

The present invention relates to a method for manufacturing a liquid crystal display device used as an image display panel such as a personal computer or a television.

[0002]

[Description of the Related Art]

A conventional method for manufacturing a liquid crystal display device will be described with reference to Figs. 5 to 8.

[0003]

In the structure of the liquid crystal display device, as shown in Fig. 5, a regular gap is held between a lower substrate 11 and an upper substrate 12 which are opposite to each other and consist of light-penetrating material, a liquid crystal material 8 is filled in the gap, and both the substrates 11 and 12 are stuck to each other by an ultraviolet ray curing type adhesive 13. The adhesive 13 contains spacers 12 for holding regular interval (for example, a diameter of 5 μm) between the upper substrate 12 and the lower substrate 1

[0004]

As a method for arranging a liquid crystal material 15 in the adhesive 13, as shown in Fig. 6, there is a liquid crystal dropping method including coating the adhesive 13 on the lower substrate 11 with a predetermined thickness (for example, 30 μm) (process a), dropping the liquid crystal material 15 in the adhesive 13 (process b), superposing the upper substrate 12 on the lower substrate 11 and pressurizing both the substrates 11 and 12 until the interval between the upper substrate 12 and the lower substrate 11 becomes a predetermined value (for example, 5 μm) (process c), and irradiating ultraviolet rays 16 to the adhesive 13 to harden the adhesive 13 (process d) to complete a liquid crystal display device.

[0005]

Hereinafter, a method for sticking two substrates will be described in detail with reference to Figs. 7 and 8.

[0006]

First, the lower substrate 11 whose upper surface is coated with an ultraviolet ray curing type adhesive 13 with a thickness of 30 μm and to which a liquid crystal material 15 is arranged in the adhesive 13 is mounted on a table 17 which can be horizontally moved, and the whole lower surface thereof is fixed by a vacuum suction force of a suction mechanism 18 (process a). Next, the upper substrate 12 is arranged so as to be opposite to the lower substrate 11 at a prescribed interval and the whole upper surface thereof is fixed by a vacuum suction force of a suction mechanism 19 (process b). Next, the upper substrate 12 is lowered so that the interval between the upper substrate 12 and the lower substrate 11 becomes 1 mm, and a vacuum container C is closed (process c). Next, the table 17 having the lower substrate 11 mounted thereon is moved in a horizontal direction, the lower substrate 11 and the upper substrate 12 are aligned and the vacuum container C is evacuated (process d). Next, the upper substrate 12 is lowered to be brought into contact with the liquid crystal material 15 or the adhesive 13, is pressurized until the interval between the lower substrate 11 and the upper substrate 12 becomes 5 μm ,

and is stuck to the lower substrate 11 through the adhesive 13 (process e). Thereafter, ultraviolet rays 16 are irradiated to the adhesive 13 to harden the adhesive 13 (process f), and thus the sticking operation of the lower substrate 11 and the upper substrate 12 is completed.

[0007]

[Problems to be Solved by the Invention]

However, in the conventional method, the upper substrate 12 and the lower substrate 11 are aligned so that the interval therebetween becomes 1 mm and then the upper substrate 12 is lowered by 1 mm to be brought into contact with the liquid crystal material 15 and the adhesive 13 and is pressurized in the vertical direction so that both the substrate are stuck to each other. Accordingly, the positional deviation is generated in the lowering and pressurizing operations.

[0008]

An object of the present invention is to provide a method for manufacturing a liquid crystal display device which can remove positional deviation when mutually sticking the lower substrate and the upper substrate and remove defect such as uneven images.

[0009]

[Means for Solving the Problems]

According to the present invention, there is provided a method for manufacturing a liquid crystal display device the steps of arranging a lower substrate whose upper surface is coated with an adhesive and to which a liquid crystal material is dropped in a vacuum container and fixing the whole lower surface of the lower substrate with vacuum suction, arranging an upper substrate so as to be opposite to the lower substrate at a prescribed interval and fixing the whole upper surface of the upper substrate with vacuum suction, approaching both or either one of the substrates to each other so as to bring the upper substrate into contact with the liquid crystal material or the adhesive, relatively moving both the substrates in a substrate surface direction to align the substrates, approaching both or either one of the substrates to each other to pressurize both the substrates to each other, and sticking both the substrates to each other. Since the alignment is performed after bringing the upper substrate into contact with the liquid crystal material and the adhesive, the state change due to the movement after the alignment is reduced and the moved distance is short. Thus, the positional deviation at the time of sticking the lower substrate and the upper substrate can be removed and thus defect such as uneven image can be removed.

[0010]

According to the present invention, there is also provided a method for manufacturing a liquid crystal display device the steps of arranging a lower substrate whose upper surface is coated with an adhesive and to which a liquid crystal material is dropped in a vacuum container and fixing the whole lower surface of the lower substrate with vacuum suction, arranging an upper substrate so as to be opposite to the lower substrate at a prescribed interval and fixing the whole upper surface of the upper substrate with vacuum suction, approaching both or either one of the substrates to each other at a prescribed interval location, relatively moving both the substrates in a substrate surface direction to perform pre-alignment, approaching both or either one of the substrates so as to bring the upper substrate into contact with the liquid crystal material or the adhesive, relatively moving both the substrates in a substrate surface direction to align the substrates, approaching both or either one of the substrates to each other to pressurize both the substrates to each other, and sticking both the substrates to each other. Thereby, the positional deviation at the time of sticking the lower substrate and the upper substrate can be removed and thus defect such as uneven image can be removed. Also, the movement amount of the lower substrate is reduced by the pre-alignment when performing the alignment and thus the adhesive is more

suppressed from being melted into the liquid crystal material.

[0011]

Also, since the upper substrate is held at a location having a micro-gap with the adhesive when bringing the upper substrate into contact with the liquid crystal material or the adhesive, the upper substrate and the lower substrate can be prevented from being tightly fixed to each other. Thus, a problem that the alignment can not be performed can be removed.

[0012]

Further, since the elastic body is interposed between the lower substrate and the suction mechanism, the gap between the upper substrate and the lower substrate can be obtained with high precision. Also, in this case, if the suction of the lower substrate is released after sticking the lower substrate and the upper substrate to each other, both the substrates are fixed by the suction mechanism of the upper substrate. Thus, the plane degree of both the substrates can be obtained with high precision.

[0013]

Moreover, since the suction of the lower substrate is released after the lower substrate and the upper substrate are stuck to each other, and the lower substrate and the upper substrate are temporarily fixed to each other by an

ultraviolet ray curing type adhesive after the pressure of the vacuum container is returned to the atmospheric pressure, the positional deviation of the upper substrate and the lower substrate can be surely prevented.

[0014]

Moreover, since the suction of the lower substrate is released and the pressure of the vacuum container is returned to the atmospheric pressure after the lower substrate and the upper substrate are stuck to each other and temporarily fixed to each other by an ultraviolet ray curing type adhesive, the positional deviation of the upper substrate and the lower substrate can be surely prevented.

[0015]

Also, since the location of at least one of the upper substrate and the lower substrate is controlled by the controlling mechanism, the upper substrate or the lower substrate can be surely fixed.

[0016]

[Description of the Embodiments]

Hereinafter, a method for manufacturing a liquid crystal display device according to a first embodiment of the present invention will be described with reference to Figs. 1 and 2.

[0017]

First, a lower substrate 3 whose upper surface is

coated with an ultraviolet ray curing type adhesive 1 with a thickness of 30 μm and to which a liquid crystal material 2 is arranged in the adhesive 1 is mounted on a table 4 which can be horizontally moved, and the whole lower surface of the lower substrate 3 is fixed by a vacuum suction force of a suction mechanism 5 (process a). Here, the lower substrate 3 consists of light-penetrating material.

[0018]

Next, the upper surface of an upper substrate 6 consisting of light-penetration material is fixed by a vacuum suction force of a suction mechanism 7, and a vacuum container C is closed and evacuated. Then, the suction mechanism 7 is lowered in the vertical direction to bring the upper substrate 6 into contact with the liquid crystal material 2 or the adhesive 1 (process b). Next, the table 4 having the lower substrate 3 mounted thereon is moved in a horizontal direction, the lower substrate 3 and the upper substrate 6 are aligned (process c)

[0019].

Next, the suction mechanism 7 is lowered in the vertical direction and the upper substrate 6 is pressurized so that the interval between the lower and upper substrates becomes 5 μm and is stuck to the lower substrate 3 through the adhesive 1 (process d). Thereafter, the substrates which are stuck to each other are carried out of the vacuum

container C and ultraviolet rays 8 are irradiated to harden to adhesive 1 (process e). Thus, the operation of sticking the lower substrate 3 and the upper substrate 6 is completed.

[0020]

According to this method, the alignment precision of the two substrates 3 and 6 which are opposite to each other can be suppressed to 1 μm or less and thus uneven images can be removed.

[0021]

Also, the thickness until the substrate is pressurized in the process d may be changed according to a diameter of spacers contained in the adhesive 1.

[0022]

Next, a method for manufacturing a liquid crystal display device according to a second embodiment of the present invention will be described with reference to Figs. 3 and 4.

[0023]

First, a lower substrate 3 whose upper surface is coated with an ultraviolet ray curing type adhesive 1 with a thickness of 30 μm and to which a liquid crystal material 2 is arranged in the adhesive 1 is mounted on a table 4 which can be horizontally moved, and the whole lower surface of the lower substrate 3 is fixed by a vacuum suction force of a suction mechanism 5 (process a). Here, the lower

substrate 3 consists of light-penetrating material.

[0024]

Next, the upper surface of a upper substrate 6 consisting of light-penetration material is fixed by a vacuum suction force of a suction mechanism 7, and a vacuum container C is closed and evacuated. Then, the upper substrate 6 is lowered so that the interval between the lower substrate 3 and the upper substrate 6 becomes 1 mm, and the table 4 having the lower substrate 3 mounted thereon is moved in the horizontal direction so that pre-alignment of the lower substrate 3 and the upper substrate 6 is performed (process b). Next, the suction mechanism 7 is lowered in the vertical direction to bring the upper substrate 6 into contact with the liquid crystal material 2 or the adhesive 1 (process c). Next, the table 4 having the lower substrate 3 mounted thereon is moved in a horizontal direction, the lower substrate 3 and the upper substrate 6 are aligned (process d)

[0025].

Next, the suction mechanism 7 is lowered in the vertical direction and the upper substrate 6 is pressurized so that the interval between the lower and upper substrates becomes 5 μm and is stuck to the lower substrate 3 through the adhesive 1 (process e). Thereafter, the substrates which are stuck to each other are carried out of the vacuum

container C and ultraviolet rays 8 are irradiated to harden to adhesive 1 (process f). Thus, the operation of sticking the lower substrate 3 and the upper substrate 6 is completed.

[0026]

According to this method, the alignment precision of the two substrates 3 and 6 which are opposite to each other can be suppressed to 1 μm or less and thus uneven images can be removed. Particularly, since the pre-alignment is performed, the movement amount of the lower substrate 3 is reduced when performing the alignment and thus the adhesive 1 is more suppressed from being melted into the liquid crystal material 2 according to the movement of the substrate.

[0027]

Also, the thickness until the substrate is pressurized in the process e may be changed according to a diameter of spacers contained in the adhesive 1.

[0028]

Further, in order to prevent the lower substrate 3 and the upper substrate 6 from being tightly fixed to each other by the adhesive 1 so that the alignment can not be performed, a mechanism for holding the gap between the upper substrate 6 and the lower substrate 3 to 100 μm from the height of the adhesive 1 may be further included so that the upper substrate 6 is brought into contact with only the liquid

crystal material 2 in the process c.

[0029]

In order to obtain the gap between the upper substrate 6 and the lower substrate 3 with high precision, an elastic body may be interposed between the lower substrate 3 and the suction mechanism 5. In case of having the elastic body, in order to obtain the plane degree of the stuck upper and lower substrates 6 and 5 with high precision, it is preferable that, after the lower substrate 3 and the upper substrate 6 are stuck to each other, the suction of the lower substrate 3 is released and the lower substrate 3 and the upper substrate 6 are fixed by the suction of the suction mechanism 7.

[0030]

Moreover, in order to prevent the deviation of the upper substrate 6 and the lower substrate 5 after the sticking operation, the suction of the lower substrate 3 may be released after sticking the lower substrate 3 and the upper substrate 6 to each other, and the upper substrate 6 and the lower substrate 3 may be temporarily fixed to each other after fixing the lower substrate 3 and the upper substrate 6 to each other by the suction of the suction mechanism 7 and returning the pressure of the vacuum container C to the atmospheric pressure.

[0031]

Also, in order to surely fix any one of the lower substrate 3 and the upper substrate 6, a mechanism for controlling the location of the substrate 3 or 6 may be further included.

[0032]

[Advantages]

According to the method for manufacturing the liquid crystal display device of the present invention, since the alignment is performed after bring the upper substrate into contact with the liquid crystal material or the adhesive, the state change due to the movement after the alignment is reduced and the moved distance is short. Thus, the positional deviation when sticking the lower substrate and the upper substrate can be removed and thus defect such as uneven image can be removed.

[0033]

Moreover, since both the substrates are approached to a prescribed interval location and the pre-alignment is performed, the positional deviation when sticking the lower substrate and the upper substrate can be removed and thus defect such as uneven image can be removed, and the movement amount of the lower substrate is reduced according to the pre-alignment when performing the alignment and thus the adhesive is more suppressed from being melted into the liquid crystal material.

[0034]

Also, since the upper substrate is held at a location having a micro-gap with the adhesive when bringing the upper substrate into contact with the liquid crystal material or the adhesive, the upper substrate and the lower substrate can be prevented from being tightly fixed to each other. Thus, a problem that the alignment can not be performed can be removed.

[0035]

Further, since the elastic body is interposed between the lower substrate and the suction mechanism, the gap between the upper substrate and the lower substrate can be obtained with high precision. Also, in this case, if the suction of the lower substrate is released after sticking the lower substrate and the upper substrate to each other, both the substrates are fixed by the suction mechanism of the upper substrate. Thus, the plane degree of both the substrates can be obtained with high precision.

[0036]

Moreover, since the suction of the lower substrate is released after the lower substrate and the upper substrate are stuck to each other, and the lower substrate and the upper substrate are temporarily fixed to each other by an ultraviolet ray curing type adhesive after the pressure of the vacuum container is returned to the atmospheric pressure,

the positional deviation of the upper substrate and the lower substrate can be surely prevented.

[0037]

Moreover, since the suction of the lower substrate is released and the pressure of the vacuum container is returned to the atmospheric pressure after the lower substrate and the upper substrate are stuck to each other and temporarily fixed to each other by an ultraviolet ray curing type adhesive, the positional deviation of the upper substrate and the lower substrate can be surely prevented.

[0038]

Also, since the location of at least one of the upper substrate and the lower substrate is controlled by the controlling mechanism, the upper substrate or the lower substrate can be surely fixed.

[Brief Description of the Drawings]

[Fig. 1]

Fig. 1 is a schematic cross-sectional view of processes of a method for manufacturing a liquid crystal display device according to a first embodiment of the present invention.

[Fig. 2]

Fig. 2 is a schematic cross-sectional view of the following processes of Fig. 1.

[Fig. 3]

Fig. 3 is a schematic cross-sectional view of processes of a method for manufacturing a liquid crystal display device according to a second embodiment of the present invention.

[Fig. 4]

Fig. 4 is a schematic cross-sectional view of the following processes of Fig. 3.

[Fig. 5]

Fig. 5 is a cross-sectional view schematically showing the structure of a liquid crystal display device.

[Fig. 6]

Fig. 6 is a schematic cross-sectional view of processes of a liquid dropping method of a liquid crystal display device.

[Fig. 7]

Fig. 7 is a schematic cross-sectional view of processes of a conventional method for manufacturing a liquid crystal display device.

[Fig. 8]

Fig. 8 is a schematic cross-sectional view of the following processes of Fig. 7.

[Reference Numerals]

- 1: adhesive
- 2: liquid crystal material
- 3: lower substrate

5: suction mechanism

6: upper substrate

7: suction mechanism

8: ultraviolet rays

(51)Int. Cl. 7	識別記号	F I	テ-マ-コ-ド (参考)
G02F 1/1339	505	G02F 1/1339	2H088
1/13	101	1/13	2H089

審査請求 未請求 請求項の数 8 O L (全7頁)

(21)出願番号	特願平10-324605	(71)出願人	000005821 松下電器産業株式会社 大阪府門真市大字門真1006番地
(22)出願日	平成10年11月16日(1998.11.16)	(72)発明者	江上 典彦 大阪府門真市大字門真1006番地 松下電器産業株式会社内
		(72)発明者	外園 信貴 大阪府門真市大字門真1006番地 松下電器産業株式会社内
		(74)代理人	100080827 弁理士 石原 勝

最終頁に続く

(54)【発明の名称】 液晶表示素子の製造方法

(57)【要約】

【課題】 下基板と上基板の貼り合わせ時の位置ずれを無くし、画像むら不良を無くすることができる液晶表示素子の製造方法を提供する。

【解決手段】 上面に接着剤1が塗布され液晶材料2が滴下された下基板3を真空容器C内に配置して下側の全面を吸着機構5にて真空吸着して固定し、下基板3に対向するように所定の間隔で上基板6を配置して上側の全面を吸着機構7にて真空吸着して固定し、両方又は一方の基板3、6を接近移動させて上基板6と液晶材料2又は接着剤1を接触させた後、両基板3、6を基板面方向に相対移動させて位置合わせを行い、その後両方又は一方の基板3、6を接近移動させて相互に加圧し、両基板3、6を貼り合わせる。

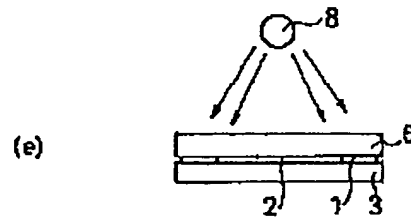
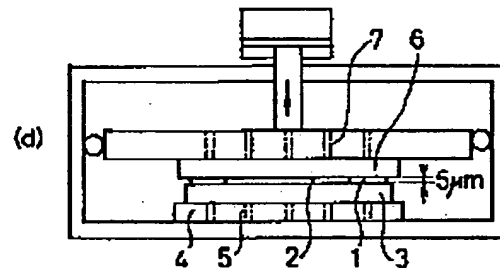

6...塗布層

【特許請求の範囲】

【請求項1】 上面に接着剤が塗布され液晶材料が滴下された下基板を真空容器内に配置して下側の全面を真空吸着して固定し、下基板に対向するように所定の間隔で上基板を配置して上側の全面を真空吸着して固定し、両方又は一方の基板を接近移動させて上基板と液晶材料又は接着剤を接触させた後、両基板を基板面方向に相対移動させて位置合わせを行い、その後両方又は一方の基板を接近移動させて相互に加圧し、両基板を貼り合わせることを特徴とする液晶表示素子の製造方法。

【請求項2】 上面に接着剤が塗布され液晶材料が滴下された下基板を真空容器内に配置しその下側の全面を真空吸着して固定し、下基板に対向するように所定の間隔で上基板を配置しその上側の全面を真空吸着して固定し、両方又は一方の基板を所定間隔位置まで接近移動させ、両基板を基板面方向に相対移動させて予備位置合わせを行い、その後両方又は一方の基板を接近移動させて上基板と液晶材料又は接着剤を接触させた後、両基板を基板面方向に相対移動させて位置合わせを行い、その後両方又は一方の基板を接近移動させて相互に加圧し、両基板を貼り合わせることを特徴とする液晶表示素子の製造方法。

【請求項3】 上基板と液晶材料又は接着剤を接触させる工程時に、上基板を接着剤との間に微小隙間が生じる位置に維持することを特徴とする請求項1又は2記載の液晶表示素子の製造方法。

【請求項4】 下基板と真空吸着する機構との間に弾性体を介装することを特徴とする請求項1又は2記載の液晶表示素子の製造方法。

【請求項5】 下基板と上基板を貼り合わせた後、下基板の吸着を解除することを特徴とする請求項4記載の液晶表示素子の製造方法。

【請求項6】 下基板と上基板を貼り合わせた後下基板の吸着を解除し、真空容器内の圧力を大気開放した後、UV硬化接着剤により仮止めを行うことを特徴とする請求項1又は2に記載の液晶表示素子の製造方法。

【請求項7】 下基板と上基板を貼り合わせ、UV硬化接着剤により仮止めを行った後、下基板の吸着を解除し、真空容器内の圧力を大気開放することを特徴とする請求項1又は2記載の液晶表示素子の製造方法。

【請求項8】 上基板と下基板の少なくとも一方の位置を規制機構にて規制することを特徴とする請求項1又は2記載の液晶表示素子の製造方法。

【発明の詳細な説明】

【0001】

【発明の属する技術分野】本発明は、パーソナルコンピュータやTV受像機等の画像表示パネルとして用いられる液晶表示素子の製造方法に関するものである。

【0002】

【従来の技術】従来の液晶表示素子の製造方法につい

て、図5～図8を参照して説明する。

【0003】液晶表示素子の構造は、図5に示すように、対向配置された透光性材料からなる下基板11と上基板12との間に一定のギャップを保つとともにその間の空間に液晶材料15を充填した状態で両者が紫外線硬化型の接着剤13にて貼り合わされている。接着剤13には下基板11と上基板12の間隔を一定に保つためのスペーサ14(径5 μ m)が含まれている。

【0004】このように液晶材料15を接着剤13の内側に配置する一方法として、図6に示すように、下基板11に接着剤13を厚み30 μ mで塗布した後(工程a)、接着剤13の内側に液晶材料15を滴下し(工程b)、次に上基板12を重ね合わせて上基板12と下基板11の間隔が5 μ mになるまで加圧し(工程c)、その後紫外線16により接着剤13を硬化させて液晶表示素子を完成させる液晶滴下工法がある。

【0005】以下、上記2枚の基板の貼り合わせ方法について、図7、図8を参照して詳しく説明する。

【0006】まず、表面に厚み30 μ mで塗布された紫外線硬化型の接着剤13及びその接着剤13の内側に液晶材料15が配置された下基板11を、水平方向に移動可能なテーブル17上に搭載し、その下側の全面を吸着機構18による真空吸着で固定する(工程a)。次に、下基板11に対向するように所定の間隔で上基板12を配置してその上側の全面を吸着機構19による真空吸着で固定する(工程b)。次に、上基板12を降下させて上基板12と下基板11の間隔を1mmにして真空容器Cを閉じる(工程c)。次に、下基板11を搭載したテーブル17を水平移動して、下基板11と上基板12との位置合わせを行うとともに、真空容器C内の真空引きを行う(工程d)。次に、上基板12を降下させて上基板12と液晶材料15又は接着剤13と接触させ、さらに下基板11との間隔が5 μ mになるまで加圧し、上基板12を接着剤13を介して下基板11に貼り合わせる(工程e)。その後、紫外線16を照射して接着剤13を硬化させ(工程f)、下基板11と上基板12の貼り合わせが完了する。

【0007】

【発明が解決しようとする課題】しかしながら、このような従来の方法では上基板12と下基板11の間隔を1mmにして位置合わせを行い、その後上基板12を1mm降下させて上基板12を液晶材料15と接着剤13に接触させ、さらに上基板12を垂直方向に加圧して貼り合わせるため、その降下、加圧時に位置ずれが発生するという問題があった。

【0008】本発明は、上記従来の問題点に鑑み、下基板と上基板の貼り合わせ時の位置ずれを無くし、画像むら不良を無くすることができる液晶表示素子の製造方法を提供することを目的とする。

【0009】

【課題を解決するための手段】本発明の液晶表示素子の製造方法は、上面に接着剤が塗布され液晶材料が滴下された下基板を真空容器内に配置して下側の全面を真空吸着して固定し、下基板に対向するように所定の間隔で上基板を配置して上側の全面を真空吸着して固定し、両方又は一方の基板を接近移動させて上基板と液晶材料又は接着剤を接触させた後、両基板を基板面方向に相対移動させて位置合わせを行い、その後両方又は一方の基板を接近移動させて相互に加圧し、両基板を貼り合わせるものであり、上基板と液晶材料又は接着剤を接触させた後位置合わせを行うため、位置合わせ後の移動時の状態変化が少なくかつ移動距離が短いため、下基板と上基板の貼り合わせ時の位置ずれを無くして画像むら不良を無くすることができる。

【0010】また、上面に接着剤が塗布され液晶材料が滴下された下基板を真空容器内に配置しその下側の全面を真空吸着して固定し、下基板に対向するように所定の間隔で上基板を配置しその上側の全面を真空吸着して固定し、両方又は一方の基板を所定間隔位置まで接近移動させ、両基板を基板面方向に相対移動させて予備位置合わせを行い、その後両方又は一方の基板を接近移動させて上基板と液晶材料又は接着剤を接触させた後、両基板を基板面方向に相対移動させて位置合わせを行い、その後両方又は一方の基板を接近移動させて相互に加圧し、両基板を貼り合わせるものであり、同様に下基板と上基板の貼り合わせ時の位置ずれを無くすることができ画像むら不良を無くすることができるとともに、予備位置決めによって位置決め時の移動量が少なくなるため接着剤の液晶材料への溶け込みを抑制できる。

【0011】また、上基板と液晶材料又は接着剤を接触させる工程時に、上基板を接着剤との間に微小隙間が生じる位置に維持すると、接着剤にて上基板と下基板がくっついてしまっ位置合わせができなくなる恐れを無くすることができる。

【0012】また、下基板と真空吸着する機構との間に弾性体を介装すると、下基板が上基板の形状にならって上基板と下基板のギャップを高精度に得ることができる。また、その場合に下基板と上基板を貼り合わせた後、下基板の吸着を解除すると、上基板の吸着機構に両基板が固定されることにより、両基板の平面度を高精度に得ることができる。

【0013】また、下基板と上基板を貼り合わせた後下基板の吸着を解除し、真空容器内の圧力を大気開放した後、UV硬化接着剤により仮止めを行うと、貼り合わせ後上基板と下基板がずれるのを確実に防止できる。

【0014】また、下基板と上基板を貼り合わせ、UV硬化接着剤により仮止めを行った後、下基板の吸着を解除し、真空容器内の圧力を大気開放すると、貼り合わせ後上基板と下基板がずれるのを確実に防止できる。

【0015】また、上基板と下基板の少なくとも一方の

位置を規制機構にて規制すると、上基板又は下基板の固定を確実なものにできる。

【0016】

【発明の実施の形態】以下、本発明の液晶表示素子の製造方法の第1の実施形態を図1、図2を参照して説明する。

【0017】まず、表面に厚み30 μ mで塗布された紫外線硬化型の接着剤1及びその接着剤1の内側に液晶材料2が配置された透光性材料からなる下基板3を、水平方向に移動可能なテーブル4上に搭載し、下基板3の下側の全面を吸着機構5による真空吸着で固定する(工程a)。

【0018】次に、透光性材料からなる上基板6の上側の全面を吸着機構7による真空吸着で固定し、真空容器Cを閉じて真空引きを行い、吸着機構7を垂直方向に下降させて、上基板6と液晶材料2または接着剤1を接触させる(工程b)。次に、下基板3を搭載したテーブル4を水平方向に移動させて、下基板3と上基板6との位置合わせを行う(工程c)。

【0019】次に、吸着機構7を垂直方向に下降させて、上基板6を接着剤1を介して下基板3に貼り合わせ、5 μ mまで加圧する(工程d)。その後、真空容器Cから出し、紫外線8を照射して接着剤1を硬化させて、下基板3と上基板6の貼り合わせは完了する(工程e)。

【0020】この方法によれば、対向する位置に配置された2枚の基板3、6の位置合わせ精度を1 μ m以下に抑制でき、画像むらを無くすることができる。

【0021】また、工程dでの加圧するまでの厚さは、接着剤1に含まれているスペーサの径に応じて変更してもよい。

【0022】次に、本発明の液晶表示素子の製造方法の第2の実施形態を図3、図4を参照して説明する。

【0023】まず、表面に厚み30 μ mで塗布された紫外線硬化型の接着剤1及びその接着剤1の内側に液晶材料2が配置された透光性材料からなる下基板3を、水平方向に移動可能なテーブル4上に搭載し、下基板3の下側の全面を吸着機構5による真空吸着で固定する(工程a)。

【0024】次に、透光性材料からなる上基板6の上側の全面を吸着機構7による真空吸着で固定し、真空容器Cを閉じて真空引きを行い、上基板6を降下させて下基板3と上基板6の間隔を1mmにし、下基板3を搭載したテーブル4を水平移動させて下基板3と上基板6の予備の位置合わせをする(工程b)。次に、吸着機構7を垂直方向に下降させて、上基板6と液晶材料2または接着剤1を接触させる(工程c)。次に、下基板3を搭載したテーブル4を水平方向に移動させて、下基板3と上基板6の位置合わせを行う(工程d)。

【0025】次に、吸着機構7を垂直方向に下降させ

て、上基板6を接着剤1を介して下基板3に貼り合わせ、5 μ mまで加圧する(工程e)。その後、真空容器Cから出し、紫外線8を照射して接着剤1を硬化させて、下基板3と上基板6の貼り合わせは完了する(工程f)。

【0026】この方法によれば、対向する位置に配置された2枚の基板3、6の位置合わせ精度を1 μ m以下に抑制でき、画像むらを無くすることができる。特に、予備の位置合わせを行っているので、位置合わせ時の下基板3の移動量が少なくなるため、移動による接着剤1の液晶材料2への溶け込みをより一層抑制することができる。

【0027】また、工程eでの加圧するまでの厚さは、接着剤1に含まれているスペーサの径に応じて変更してもよい。

【0028】また、下基板3と上基板6が接着剤1でくっついてしまっ位置合わせができなくなるのを防止するため、上基板6と液晶材料2又は接着剤1を接触させる工程で液晶材料2にのみ接触させるように、上基板6と下基板3の隙間を接着剤1の高さから100 μ mに維持する機構を有してもよい。

【0029】また、上基板6と下基板3のギャップを高精度に得るため、下基板3と吸着機構5の間に弾性体を介装してもよい。弾性体を有する場合、貼り合わせ後の上基板6と下基板3の平面度を高精度に得るため、下基板3と上基板6を貼り合わせた後、下基板3の吸着を解除し、上基板6の吸着機構7による吸着で固定するのが好ましい。

【0030】また、貼り合わせた後上基板6と下基板3がずれないようにするため、下基板3と上基板6を貼り合わせた後、下基板3の吸着を解除し、上基板6の吸着機構7による真空吸着で固定し、真空容器C内の圧力を大気開放した後UV硬化接着剤により仮止めを行ってもよい。

【0031】また、下基板3と上基板6の少なくとも一方の固定を確実なものとするために、それらの基板3、6を位置規制する機構を備えてもよい。

【0032】

【発明の効果】本発明の液晶表示素子の製造方法によれば、以上のように上基板と液晶材料又は接着剤を接触させた後位置合わせを行うようにしたので、位置合わせ後の移動時の状態変化が少なくかつ移動距離が短いため、下基板と上基板の貼り合わせ時の位置ずれを無くして画像むら不良を無くすることができる。

【0033】また、両基板を所定間隔位置まで接近移動させて予備位置合わせを行った後上記のように位置合わせすると、上記と同様の効果を奏するとともに、予備位

置決めによって位置決め時の移動量が少なくなるため接着剤の液晶材料への溶け込みを抑制できる。

【0034】また、上基板と液晶材料又は接着剤を接触させる工程時に、上基板を接着剤との間に微小隙間が生じる位置に維持すると、接着剤にて上基板と下基板がくっついてしまっ位置合わせができなくなる恐れを無くすることができる。

【0035】また、下基板と真空吸着する機構との間に弾性体を介装すると、下基板が上基板の形状にならって上基板と下基板のギャップを高精度に得ることができ、またその場合に下基板と上基板を貼り合わせた後、下基板の吸着を解除すると、上基板の吸着機構に両基板が固定されることにより、両基板の平面度を高精度に得ることができる。

【0036】また、下基板と上基板を貼り合わせた後下基板の吸着を解除し、真空容器内の圧力を大気開放した後、UV硬化接着剤により仮止めを行うと、貼り合わせ後上基板と下基板がずれるのを確実に防止できる。

【0037】また、下基板と上基板を貼り合わせ、UV硬化接着剤により仮止めを行った後、下基板の吸着を解除し、真空容器内の圧力を大気開放すると、貼り合わせ後上基板と下基板がずれるのを確実に防止できる。

【0038】また、上基板と下基板の少なくとも一方の位置を規制機構にて規制すると、上基板又は下基板の固定を確実なものにできる。

【図面の簡単な説明】

【図1】本発明の液晶表示素子の製造方法における第1の実施形態の工程を示す模式的断面図である。

【図2】図1の後続工程を示す模式的断面図である。

【図3】本発明の液晶表示素子の製造方法における第2の実施形態の工程を示す模式的断面図である。

【図4】図3の後続工程を示す模式的断面図である。

【図5】液晶表示素子の概略構成を示す模式的に示す断面図である。

【図6】液晶表示素子の液晶滴下工法による製造工程を示す模式的断面図である。

【図7】従来例の液晶表示素子の製造工程を示す模式的断面図である。

【図8】図7の後続工程を示す模式的断面図である。

【符号の説明】

- 1 接着剤
- 2 液晶材料
- 3 下基板
- 5 吸着機構
- 6 上基板
- 7 吸着機構
- 8 紫外線

【図1】

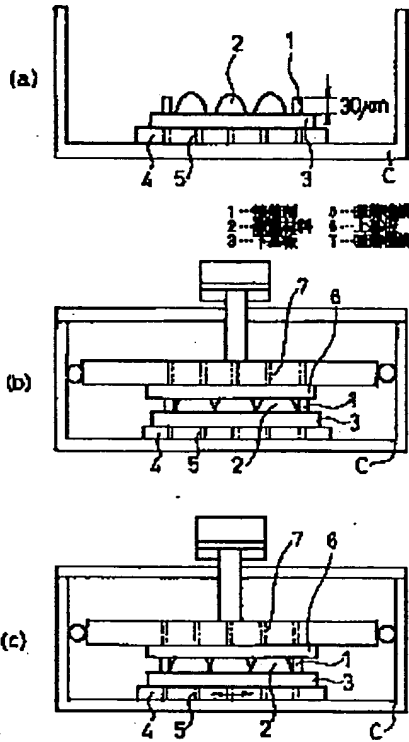

1	2	3	4	5
6	7	8	9	10
11	12	13	14	15

【図2】

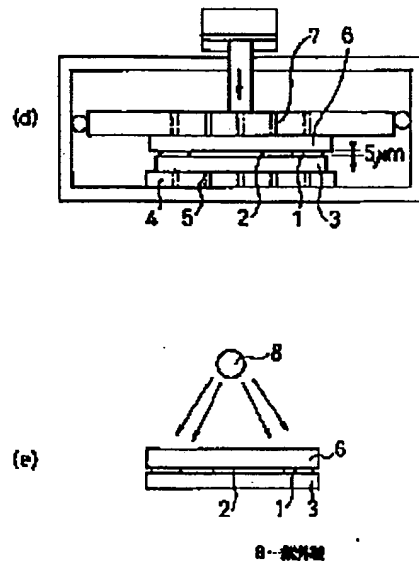

8-突起部

【図3】

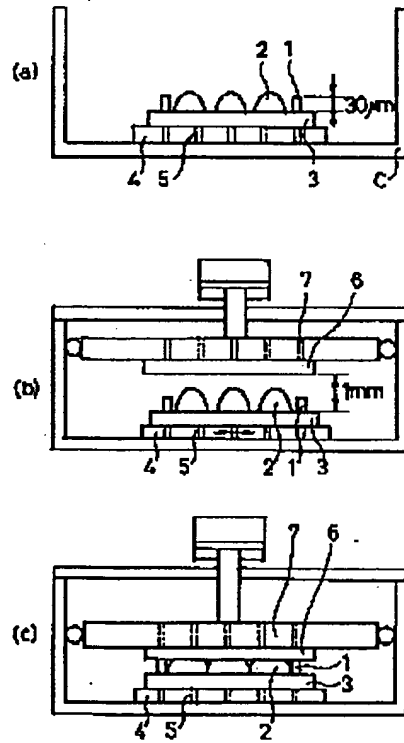

【図5】



【図4】

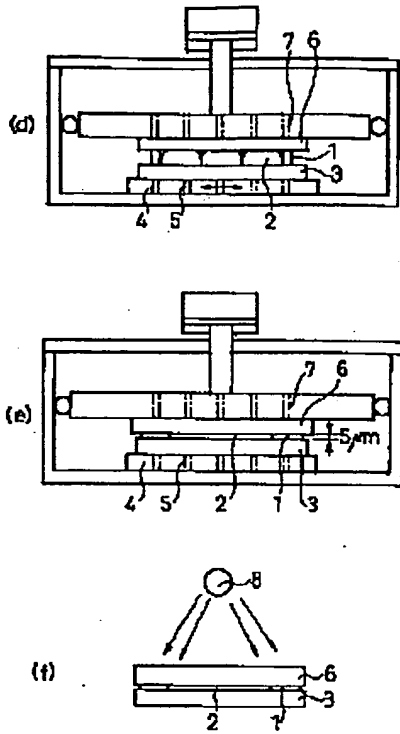

【図8】

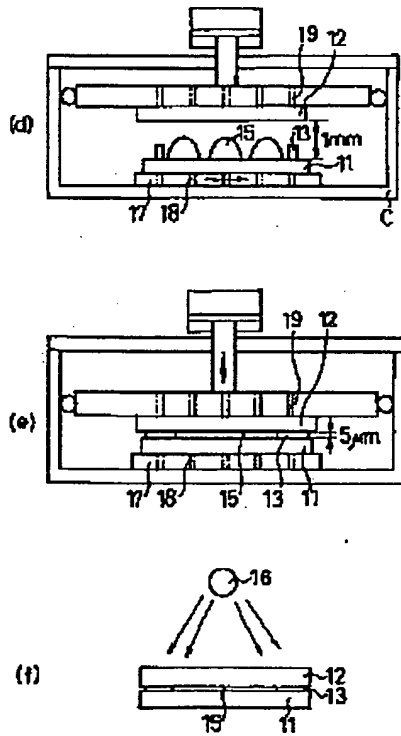

【図6】

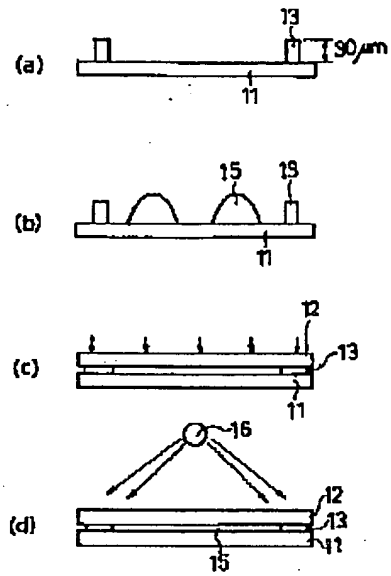

【図7】

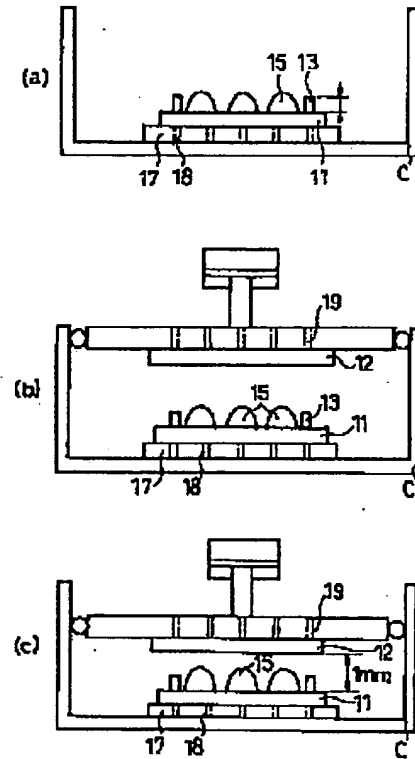

フロントページの続き

(72)発明者 井上 進
大阪府門真市大字門真1006番地 松下電器
産業株式会社内

(72)発明者 炭田 祉朗
大阪府門真市大字門真1006番地 松下電器
産業株式会社内

(72)発明者 酒井 直人
大阪府門真市大字門真1006番地 松下電器
産業株式会社内

(72)発明者 松川 秀樹
大阪府門真市大字門真1006番地 松下電器
産業株式会社内

Fターム(参考) 2H088 FA04 FA09 FA16 MA17 MA20
2H089 NA22 NA44 NA48 NA51 QA12
QA14